

# FMS500 XTCAN

GNSS VEHICLE TRACKER



---

**User manual**  
FMS500 XTCAN

## Contents

<b>1. FMS500 XTCAN general device information .....</b>	<b>3</b>
1.1. Safety and legal information .....	3
1.2. Description .....	3
1.3. Package .....	3
1.4. Technical specifications .....	4
1.5. Physical properties .....	5
1.6. Pinout & diagnostic LED .....	7
1.6.1. Pinout .....	7
1.6.2. Diagnostic LED .....	8
1.7. Installation .....	10
1.8. Configuration .....	10
1.9. Support .....	10
1.10. Document versions .....	10
<b>2. Annex 1. Installation instructions .....</b>	<b>11</b>

## 1. FMS500 XTCAN general device information

### 1.1. Safety and legal information



Do not disassemble the device.

May interfere operation of adjacent electronic devices.

Device may be damaged by water and high humidity.

Installed by qualified professionals only.

Copyright © XIRGO GLOBAL, Ltd. All rights reserved. Reproduction, transfer, distribution or storage of part or all of the contents in this document in any form without prior written permission of XIRGO GLOBAL is strictly prohibited.

### 1.2. Description

FMS500 XTCAN is a device with GNSS and Cellular connectivity, designed for object tracking. It is able to acquire information on object location, speed, direction, etc. and transfer the data via Cellular network. Digital and analog inputs of the device may be used to connect different external sensors/devices. Outputs of the device may be used to control external equipment remotely.

Flexible configuration allows users/dealers to adjust the device to meet their specific requirements. All device settings and firmwares are updated remotely via GPRS. It is possible to create setting templates for groups of vehicles, use mass updates and create unique device operation logic, fulfilling requirements of most cases on the market.

### 1.3. Package

FMS500 XTCAN is shipped to a customer in a cardboard box and contains all required components for operation, except a SIM card. Package contents:

1. FMS500 XTCAN device (control unit)
2. Wires + fuse

**Note.** SIM card is not included, but is necessary to operate the device. Contact your local Network provider to purchase a SIM card. Xirgo Global recommends an M2M SIM card for best performance and reliability.

## 1.4. Technical specifications

Table 1. FMS500 XTCAN technical specifications

<b>General</b>	Physical Peripherals
	2x CAN lines 1-Wire RS-232 EIA-485 / J1708
<b>Digital Inputs</b>	4x discrete (frequency, impulse counter, ON/OFF modes)
Voltage threshold	dynamic
<b>Analog Inputs</b>	3x analogue, 12 bit, 0-31V
<b>Outputs</b>	Open Collector type
OUT1 maximum current	0,5A
OUT2 maximum current	0,5A
<b>Power supply</b>	9 – 31V
Rated voltage	12/24 V
Average consumption (at 12V)	Full active without load on outputs: 100mA Full active with maximum load on outputs: 600mA Deep sleep: 4 mA
Internal memory	8 MB
Accelerometer	3 axis digital accelerometer
Operational temperature range	
With internal Lithium battery	from -20 to +60 C°
Without internal Lithium battery	from -40 to +85 C°
Dimensions	68x90x19 mm
Weight	Tracker – 64 g, set – 160 g
<b>Cellular and GNSS module</b>	Simcom SIM800 Ublox EVA-M8M
RF function	EGPRS
Bands/Frequency	GSM/EDGE Bands 2: 1850 – 1910 MHz (TX), 1930 – 1990 MHz (RX) GSM/EDGE Bands 3: 1710 – 1785 MHz (TX), 1805 – 1880 MHz (RX) GSM/EDGE Bands 5: 824 – 849 MHz (TX), 869 – 894 MHz (RX) GSM/EDGE Bands 8: 880 – 915 MHz (TX), 925 – 960 MHz (RX)
Transmitting power	Class 3(23dBm+2dB)
Cellular antenna	PCB antenna
GNSS	GPS GLONASS BeiDou (optional) Galileo (optional)
GNSS antenna	SMD patch antenna
GNSS antenna gain	GPS : -0.14 dBi typ. GLONASS : 1.75 dBi typ.
GNSS sensitivity	Cold start: -146dBm Reacquisition: -157dBm Tracking: -157dBm

## Physical properties

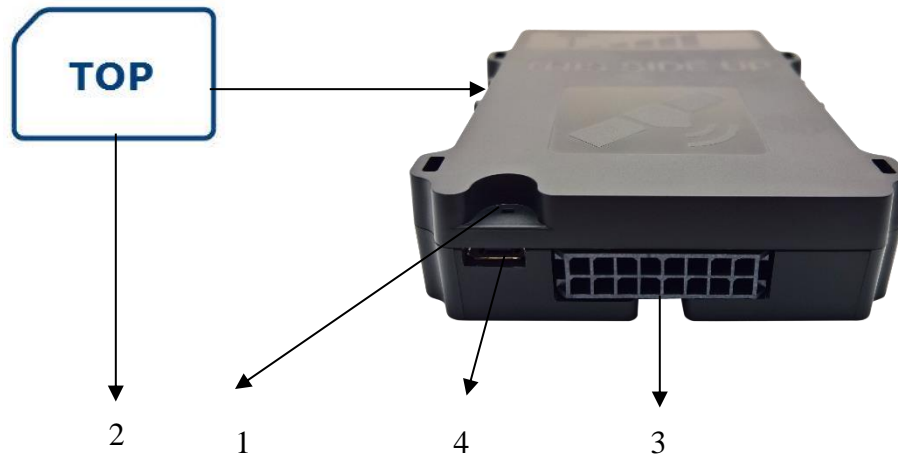

Fig. 1. FMS500 XTCAN front view.

**Note.** To insert a SIM card, open the box by lifting plastic holders from both sides.

Table 2. FMS500 XTCAN components.

No.	Short description
1	LED indicator
2	SIM card
3	Socket 2x8 pins
4	USB interface

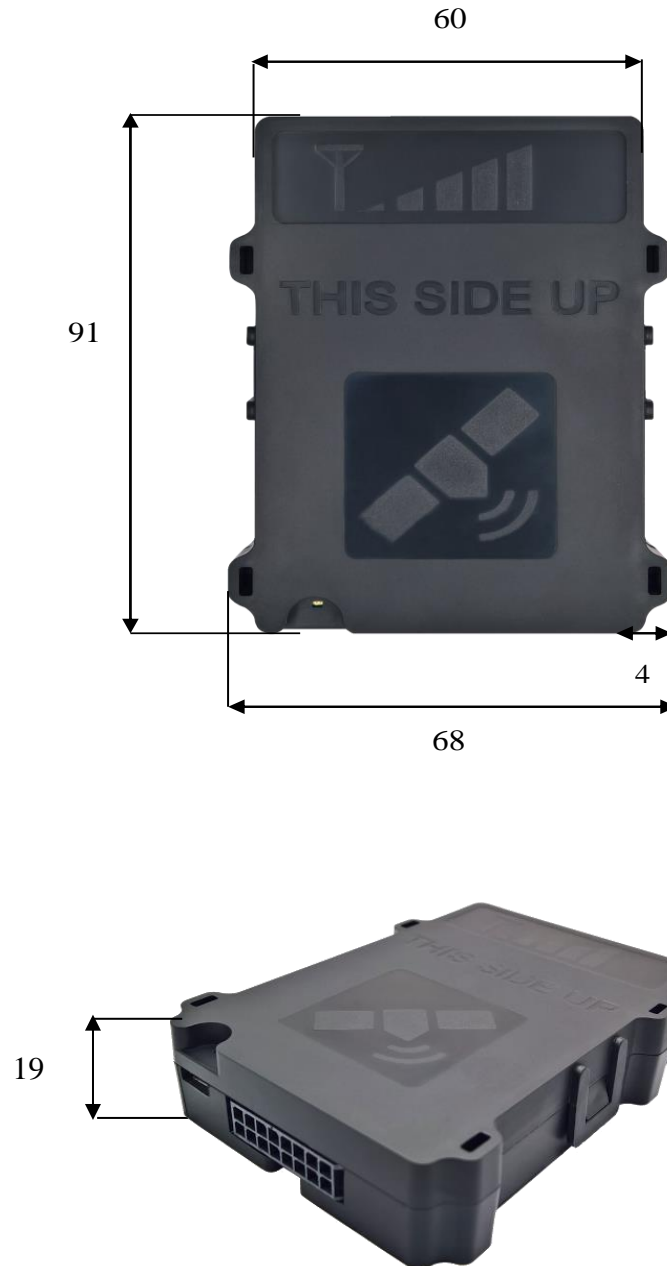

Fig. 2. FMS500 XTCAN dimensions, mm

## 1.5. Pinout & diagnostic LED

### 1.5.1. Pinout



CAN H Orange	CAN L Orange/black	OUT2/ADC3 White	IN4 Blue/black	GND Black	Battery+ Red	RS232(TX) Purple	RS232(RX) Blue
CAN2 H Yellow	CAN2 L Yellow/black	1-WIRE Brown	IN5/ADC5 Grey/black	IN3/OUT1 Purple/black	IN2/ADC4 White/black	RS485 (B) Green	RS485 (A) Green/black

Fig. 3. FMS500 XTCAN pinout and cable colors.

### 1.5.2. Diagnostic LED

FMS500 XTCAN has an indication LED – for GNSS, Cellular modem and CAN line status. LED starts flashing only if IN5 digital input is connected to battery +.

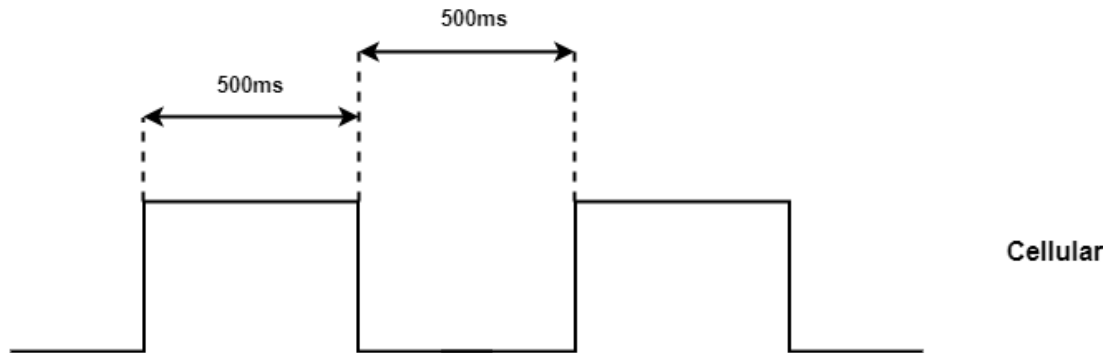

Fig 4. Cellular signal flashing example

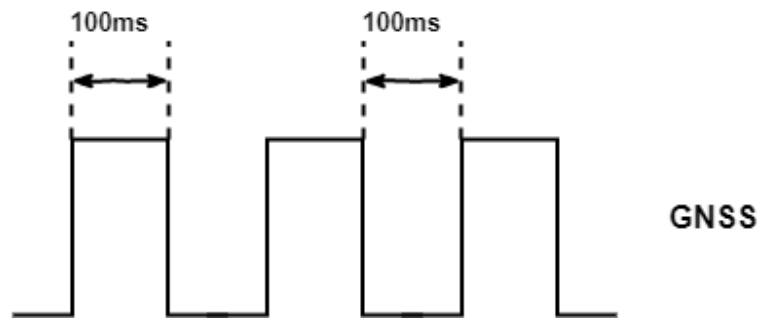

Fig 5. GNSS signal flashing example

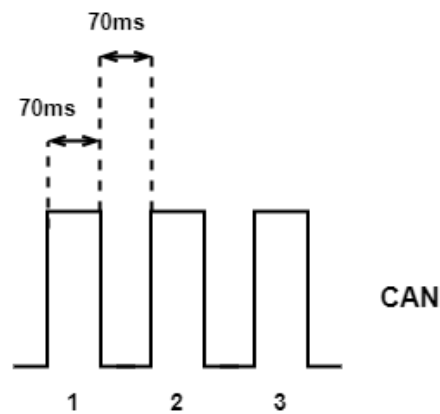

Fig 6. CAN signal flashing example

Table 3. CAN status flashing meaning

Flashes count	Meaning
1	Reading CAN1 line
2	Reading CAN2 line
3	Reading CAN1 & CAN2 lines

Table 4. GNSS status flashing meaning

Flashes count	Meaning
1	No GNSS signal
2	Poor precision. HDOP>1.5
3	3 satellites locked. HDOP<1.5
...	...
12	12 satellites locked. HDOP<1.5

Table 5. Cellular modem status flashing meaning

Flashes count	Meaning
1	Modem connected to server, Modem connected to Internet, Modem GPRS registered, Modem GSM registered, Modem SIM card ok, Modem turned on
2	Modem connected to Internet, Modem GPRS registered, Modem GSM registered, Modem SIM card ok, Modem turned on
3	Modem GPRS registered, Modem GSM registered, Modem SIM card ok, Modem turned on
4	Modem GSM registered, Modem SIM card ok, Modem turned on
5	Modem SIM card ok, Modem turned on
6	Modem turned on
7	Device started

## 1.6. Installation

FMS500 XTCAN is installed where risk of mechanical damage, high humidity and extreme heat is low. Device is mounted stable to vehicle body, therefore ensuring correct operation of the internal accelerometer. Complete installation manual is available as Annex 1.

## 1.7. Configuration

FMS500 XTCAN is to be configured via a configuration server, where dealers/users can adjust operation of their devices to fulfill specific requirements.

## 1.8. Support

FMS500 XTCAN is built to be a reliable, stable and easy to install device. Please read and follow provided installation and operating instructions carefully. However, if you encounter difficulties while installing or using this product, technical support is available and may be reached by e-mail [support@xirgo.com](mailto:support@xirgo.com) or [tech\\_support@xirgo.com](mailto:tech_support@xirgo.com).

## 1.9. Document versions

Table 6. Document versions

Version	Date	Changes
1.0	2017-07-04	Document created.
2.0	2020-04-23	Specifications table updated. Diagnostic LED section updated Installation instructions updated

## 2. Annex 1. Installation instructions

### General

Central unit is only mounted in inside of the vehicle, it can not be installed in the engine chamber, next to the cabin, or in the area of exposure to direct external conditions. Central unit should be protected from moisture exposure. Device must be fastened in a stable position to avoid random twitches and displacements (suspension on cables is strictly prohibited). Central unit must be mounted horizontally. Precise orientation is of particular importance to flawless operation of the system, since the device is equipped with acceleration sensors recording the data which directly affects the results obtained.

### List of suitable vehicles

FMS500 XTCAN is intended for internal combustion engines, hybrid and electric engines, where power supply specifications are met. Device must be connected to the vehicle battery, ensuring constant power supply even if the engine is not working and ignition is off.

### Basic instructions before beginning the installation

Quality of connections, location of the device, etc. play a significant role on accurate operation of the system. Below are some tips and rules for correct installation to attain professional quality and ensure maximum efficiency of the device.

### Mechanical connections

To highest possible extent, cavities in the vehicle should be used for wiring. If you need to make a new hole, it must be protected against corrosion appropriately!

Wiring connection must be made by brazing, and not merely mechanical wire connection. It is especially important to protect the connections with insulation for high-resistance atmospheric conditions. Do not use insulation with unknown resistance parameters.

Efforts should be made to tie the new wiring into the car's standard wiring bales.

### ***Installation of central unit***

Steps to install central unit:

1. Open the housing by gently lifting the plastic holders on each side and remove the PCB from it.
  - Use thin screwdriver to lift up the plastic holders in order not to brake them.
2. Locate the SIM holder and following the printed picture on the PCB insert the SIM card.
3. Place the PCB to the housing and close it.
4. Use plastic fastening straps to fix device in a stable position (units housing has four holes, for straps to go through and fasten them to the body of the vehicle).
5. Connect power supply;
6. Connect ignition wire to a digital input (usually IN5);
7. Connect array;
8. Connect other devices (optional).

### ***Tools/equipment necessary for the installation:***

1. Pliers
2. Stripping pliers
3. Screwdriver
4. Multimeter (tester)
5. Fastening straps
6. Isolation tape

### *Principle connection scheme*

- 1A fuse on power wire is mandatory to meet all safety requirements
- We strictly recommend to put not less than 1A fuses when connecting any additional device (f.e. relay) to device outputs

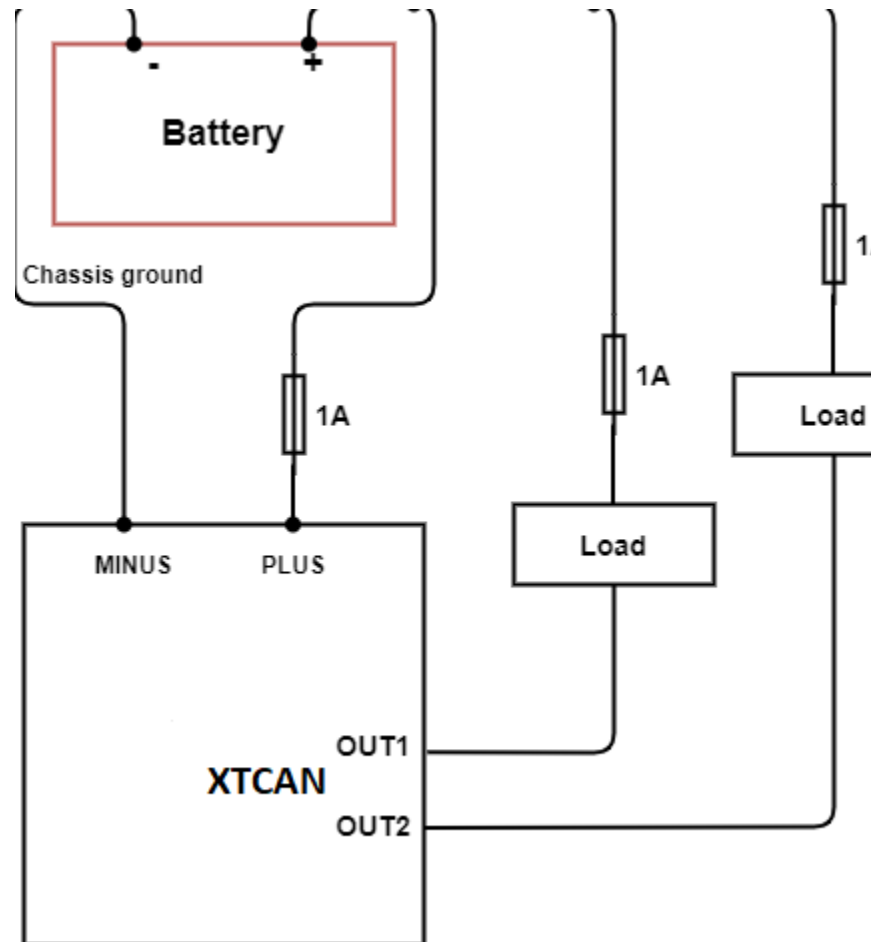

Fig.7 Principle connection scheme

### **SIM card**

SIM card must be inserted into the device before starting installation. The device must be turned off when inserting SIM card. Before inserting the SIM card, make sure you have all network services activated, the card's PIN code must be disabled.

If the vehicle is travelling to foreign countries, roaming service must be activated for the SIM card. The SIM card and phone number must be checked and clearly marked on the installation certificate of the device.

***IMPORTANT!*** Before inserting a SIM card, do not forget to disable PIN code. Otherwise, the device will not work, and the SIM card will be blocked.

## **GNSS antenna**

GNSS antenna is the main element responsible for vehicle positioning accuracy and quality. FMS500 XTCAN units are equipped with internal GNSS antennas. To ensure best possible signal reception and evaluating GNSS signal character, there are strict requirements for correct installation of the tracking unit:

- The accordingly marked side of the device must be invariably directed to the sky. The device must be oriented horizontally (not at an angle) and oriented with the corresponding side towards the top.
- The device should not be covered with metal sheet or reinforced glass. In vehicles with standard glass (e.g., without built-in heating elements).
- Fixing of the device must be stable and immobile, providing for the installation durability. It is necessary to take into account events, which may lead to loss of device stability, to select the mounting location and methods that would allow to avoid these factors.

## **Cellular antenna**

Cellular antenna is responsible for transfer of collected data and connection with central server. Good antenna's performance is the key element in obtaining information from the device. FMS500 XTCAN series trackers are equipped with internal Cellular antennas.

Cellular antenna does not require orientation to open sky; however you should be aware that metal elements weaken the GSM signal. It is also necessary to take into account the emission of the antenna's high frequency radio waves, which may interfere with operation of electronic devices.